

## Worldwide Locations

### U.S.A

**Sumitomo Machinery Corporation of America (SMA)**  
4200 Holland Blvd. Chesapeake, VA 23323, U.S.A.  
TEL (1)757-485-3355 FAX (1)757-485-7490

### Canada

**SM Cyclo of Canada, Ltd. (SMC)**  
1453 Cornwall Road, Oakville, Canada ON L6J 7T5  
TEL (1)905-469-1050 FAX (1)905-469-1055

### Mexico

**SM Cyclo de Mexico, S.A. de C.V. (SMME)**  
Av. Desarrollo 541, Col. Finsa, Guadalupe, Nuevo León, México, CP67132  
TEL (52)81-8144-5130 FAX (52)81-8144-5130

### Brazil

**Sumitomo Industrias Pesadas do Brasil Ltda. (SHIB)**  
Rodovia do Acucar (SP-075) Km 26  
Itu, Sao Paulo, Brasil  
TEL (55)11-4886-1000 FAX (55)11-4886-1000

### Chile

**SM-Cyclo de Chile Ltda. (SMCH)**  
San Pablo 3507, Quinta Normal, Santiago, Chile  
TEL (56)2-892-7000 FAX (56)2-892-7001

### Argentina

**SM-Cyclo de Argentina S.A. (SMAR)**  
Ing. Delpini, 2236 Area de Promocion el Triangulo, Partido Malvinas Argentinas Grand Bourg, Buenos Aires, Argentina B1615KGB  
TEL (54)3327-45-4095 FAX (54)3327-45-4099

### Guatemala

**SM Cyclo de Guatemala Ensambladora, Ltda. (SMGT)**  
Parque Industrial Unisur, 0 Calle B 19-50 Zona 3, Bodega D-1 Delta Bárcenas en Villa Nueva, Guatemala  
TEL (502)6648-0500 FAX (502)6631-9171

### Colombia

**SM Cyclo Colombia, S.A.S. (SMCO)**  
Carrera 11, No.93A-53, Office 203, Bogotá, Colombia  
TEL (57)1-3000673

### Germany

**Sumitomo (SHI) Cyclo Drive Germany GmbH (SCG)**  
Cyclostraße 92, 85229 Markt Indersdorf, Germany  
TEL (49)8136-66-0 FAX (49)8136-5771

### Austria

**Sumitomo (SHI) Cyclo Drive Germany GmbH (SCG)**  
SCG Branch Austria Office  
Gruentalerstraße 30A, 4020 Linz, Austria  
TEL (43)732-330958 FAX (43)732-331978

### Belgium

**Sumitomo (SHI) Cyclo Drive Germany GmbH (SCG)**  
SCG Branch Benelux Office  
Heikneuterlaan 23, 3010 Kessel-Lo, Leuven, Belgium  
TEL (32)16-60-83-11 FAX (32)16-60-16-39

### France

**SM-Cyclo France SAS (SMFR)**  
8 Avenue Christian Doppler, 77700 Serris, France  
TEL (33)164171717 FAX (33)164171718

### Italy

**SM-Cyclo Italy Srl (SMIT)**  
Via dell' Artigianato 23, 20010 Cornaredo (MI), Italy  
TEL (39)293-481101 FAX (39)293-481103

### Spain

**SM-Cyclo Iberia, S.L.U. (SMIB)**  
C/Landabari No. 3, 6<sup>o</sup> B. 48940 Leioa, Vizcaya, Spain  
TEL (34)9448-05389 FAX (34)9448-01550

### Sweden

**Sumitomo (SHI) Cyclo Drive Germany GmbH Sales Office Nordic BRO (SCG)**  
Dagsverkarvägen 14, 19736 BRO, Sweden  
TEL (46)40220031

### United Kingdom

**SM-Cyclo UK Ltd. (SMUK)**  
Unit 29, Bergen Way, Sutton Fields Industrial Estate, Kingston upon Hull, HU7 0YQ, East Yorkshire, United Kingdom  
TEL (44)1482-790340 FAX (44)1482-790321

### Turkey

**SM Cyclo Turkey Güç Aktarım Sis. Tic. Ltd. Sti. (SMTR)**  
Büyükdere Çayırbaşı Cd. Dede Yusuf Sk. No: 11, 34453 Sarıyer Istanbul, Turkey  
TEL (90)216-384-4482 FAX (90)216-384-4482

### China

**Sumitomo (SHI) Cyclo Drive China, Ltd. (SCT)**  
11F, SMEG Plaza, No. 1386 Hongqiao Road, Changning District, Shanghai, China (P.C. 200336)  
TEL (86)21-3462-7877 FAX (86)21-3462-7922

### Hong Kong

**SM-Cyclo of Hong Kong Co., Ltd. (SMHK)**  
Rm 1301, CEO Tower, 77 Wing Hong Street, Cheung Sha Wan, Kowloon, Hong Kong  
TEL (852)2460-1881 FAX (852)2460-1882

### Korea

**Sumitomo (SHI) Cyclo Drive Korea, Ltd. (SCK)**  
Royal Bldg. 9F Rm. 913, 5 Dangju-Dong, Chongno-Ku, Seoul, Korea 03173  
TEL (82)2-730-0151 FAX (82)2-730-0156

### Taiwan

**Tatung SM-Cyclo Co., Ltd. (TSC)**  
22 Chungshan N. Road 3rd., Sec. Taipei, Taiwan 104, R.O.C.  
TEL (886)2-2595-7275 FAX (886)2-2595-5594

### Singapore

**Sumitomo (SHI) Cyclo Drive Asia Pacific Pte. Ltd. (SCA)**  
15 Kwong Min Road, Singapore 628718  
TEL (65)6591-7800 FAX (65)6863-4238

### Philippines

**Sumitomo (SHI) Cyclo Drive Asia Pacific Pte. Ltd. (SCA)**  
Philippines Branch Office  
B2B Granville Industrial Complex, Carmona, Cavite 4116, Philippines  
TEL (63)2-584-4921 FAX (63)2-584-4922  
TEL (63)46-430-3591  
TEL (63)46-682-0580

### Vietnam

**SM-Cyclo (Vietnam) Co., Ltd. (SMVN)**  
Factory 2B, Lot K1-2-5, Road No. 2-3-5A, Le Minh Xuan Industrial Park, Binh Chanh Dist., HCMC, Vietnam  
TEL (84)8-3766-3709 FAX (84)8-3766-3710

### Malaysia

**SM-Cyclo (Malaysia) Sdn. Bhd. (SMMA)**  
No.7C, Jalan Anggerik Mokara 31/56, Kota Kemuning, Seksyen 31, 40460 Shah Alam, Selangor Darul Ehsan, Malaysia  
TEL (60)3-5121-0455 FAX (60)3-5121-0578

### Indonesia

**PT. SM-Cyclo Indonesia (SMID)**  
Jalan Sungkai Blok F 25 No. 09 K, Delta Silicon III, Lippo Cikarang, Bekasi 17530, Indonesia  
TEL (62)21-2961-2100 FAX (62)21-2961-2211

### Thailand

**SM-Cyclo (Thailand) Co., Ltd. (SMTH)**  
195 Empire Tower, Unit 2103-4, 21st Floor, South Sathorn Road, Yannawa, Sathorn, Bangkok 10120, Thailand  
TEL (66)2670-0998 FAX (66)2670-0999

### Australia

**Sumitomo (SHI) Hansen Australia Pty. Ltd. (SHAU)**  
181 Power St, Glendenning, NSW 2761, Australia  
TEL (61)2-9208-3000 FAX (61)2-9208-3050

### India

**Sumi-Cyclo Drive India Private Limited (SMIN)**  
Survey No. 130, Hissa No. 02, Jeevan Nagar, Off Mumbai-Bangalore Bypass, Tathawade, Pune - 411033, India  
TEL (91)20-6674-2900 FAX (91)20-6674-2901

### Japan

**Sumitomo Heavy Industries, Ltd. (SHI)**  
ThinkPark Tower, 1-1 Osaki 2-chome, Shinagawa-ku, Tokyo 141-6025, Japan  
TEL (81)3-6737-2511 FAX (81)3-6866-5160

# Sumitomo Drive Technologies

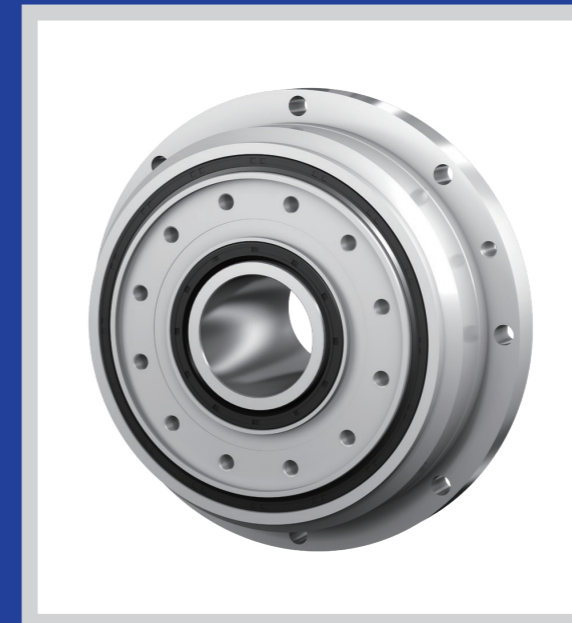

## Motion Control Drives FINE CYCLO® High Precision Gearboxes C series

Specifications, dimensions, and other items are subject to change without prior notice.

## Sumitomo Heavy Industries, Ltd.

### Power Transmission & Controls Group

Headquarter ThinkPark Tower, 1-1 Osaki 2-chome, Shinagawa-ku, Tokyo 141-6025, Japan

## No.F2003E-4.0

EA06 Printed 2017.07

## Sumitomo Heavy Industries, Ltd.

No.F2003E-4



## Table of Contents

1. Construction.....	3
2. Nomenclature.....	4
3. Products.....	4
4. Speed Ratio & Rotation Direction.....	4
5. Standard Specifications.....	5
6. Application Examples.....	5
7. Rating.....	6
8. Engineering Data.....	8
9. Main Bearings.....	11
10. Selection.....	12
11. Notice for Designing.....	14
12. Outline Drawing.....	16
13. Operating Principles.....	19
Warranty Standard	

Motion Control Drives  
FINE CYCLO®

# C series

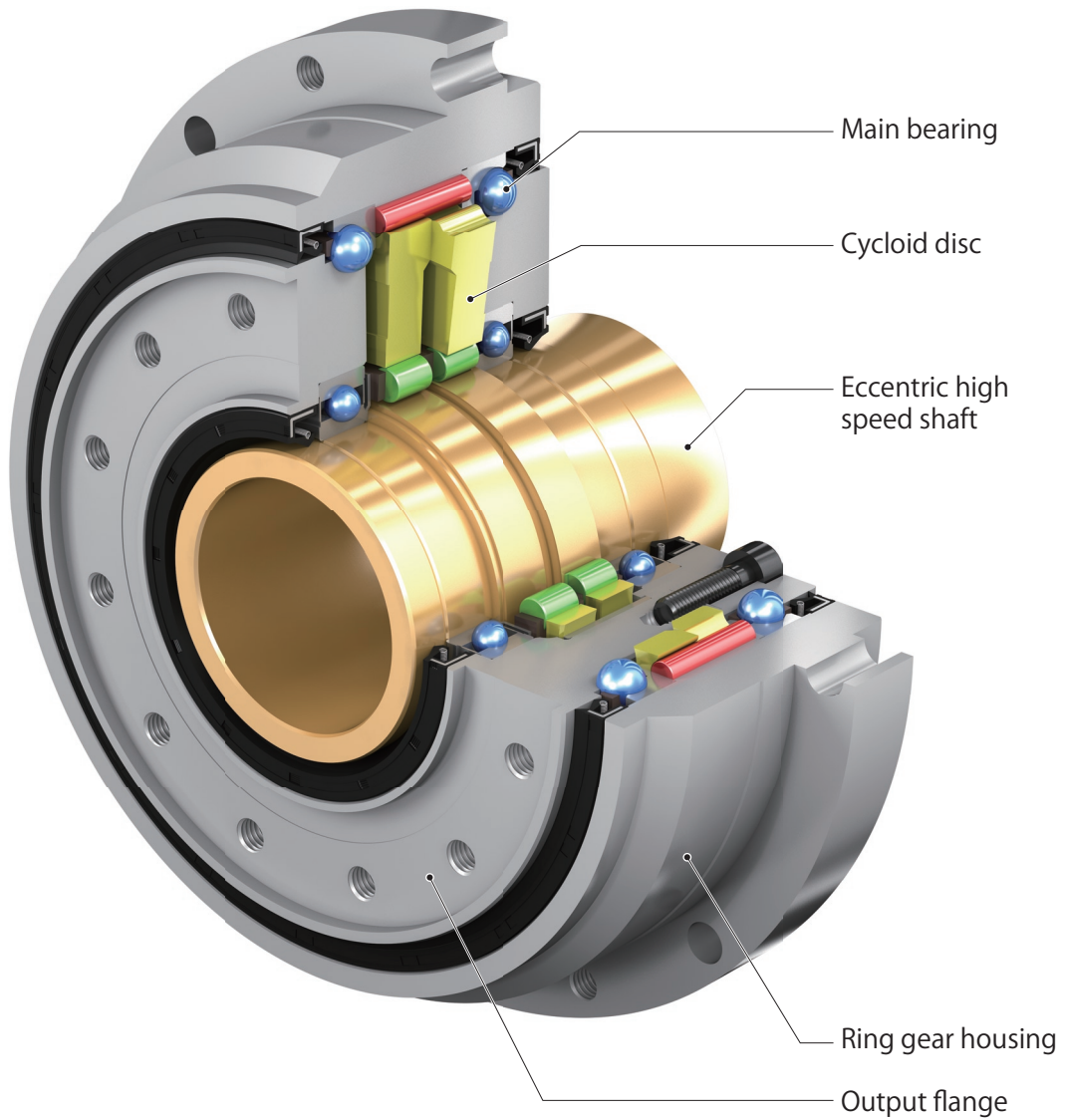

### Large Hollow Bore

Enlarged hollow diameter enables effective use of space for cable or shaft.

### Reduces Man-Hour for Assembly

High-speed shaft supported by the reducer simplifies coupling with motor.

### Complete Sealed Design

Grease is sealed inside the reducer. Customers are released from the sealing work.

### Compact Design

Single stage reducer mechanism enables simple construction with less number of parts.

# 1. Construction

F4C-C, F4CF-C Type (Frame size C15, C25, C35, C45)

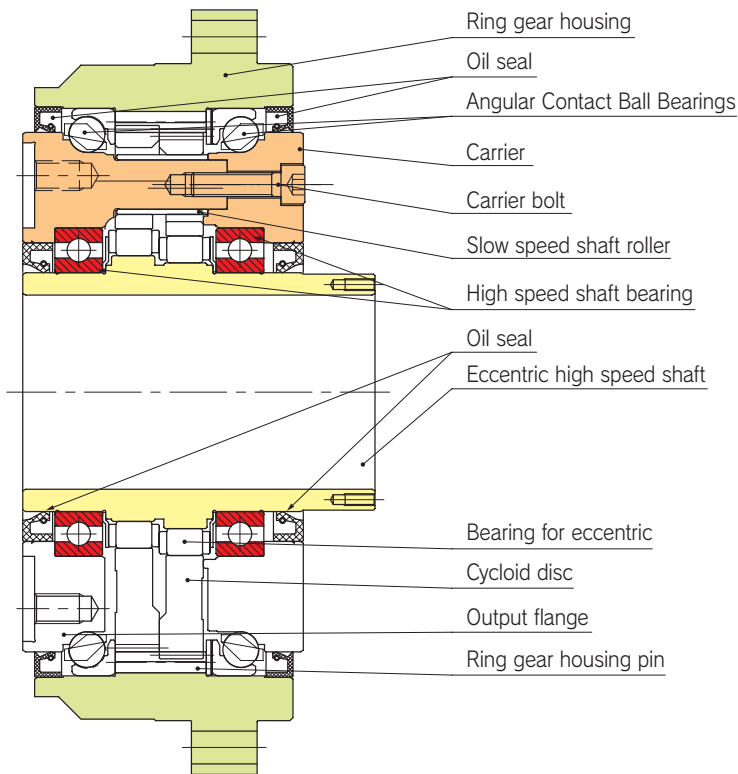

F2CF-C Type (Frame size C55, C65)

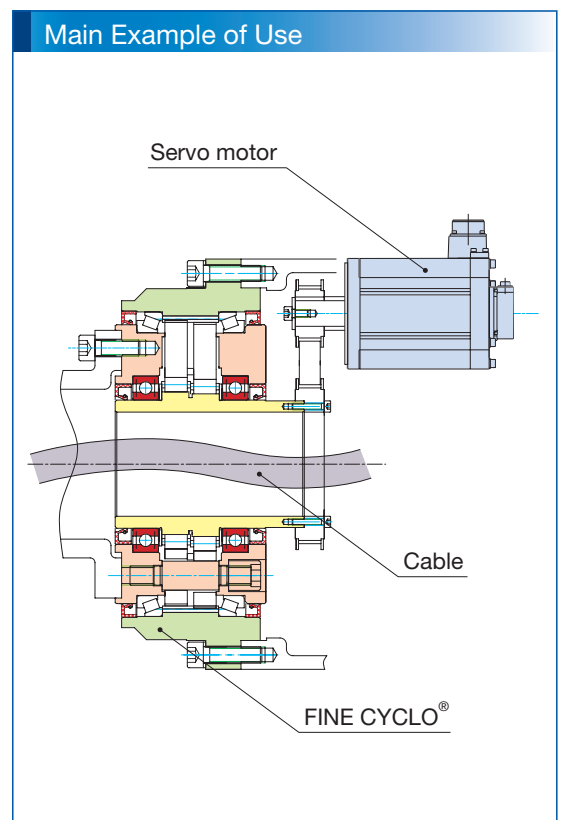
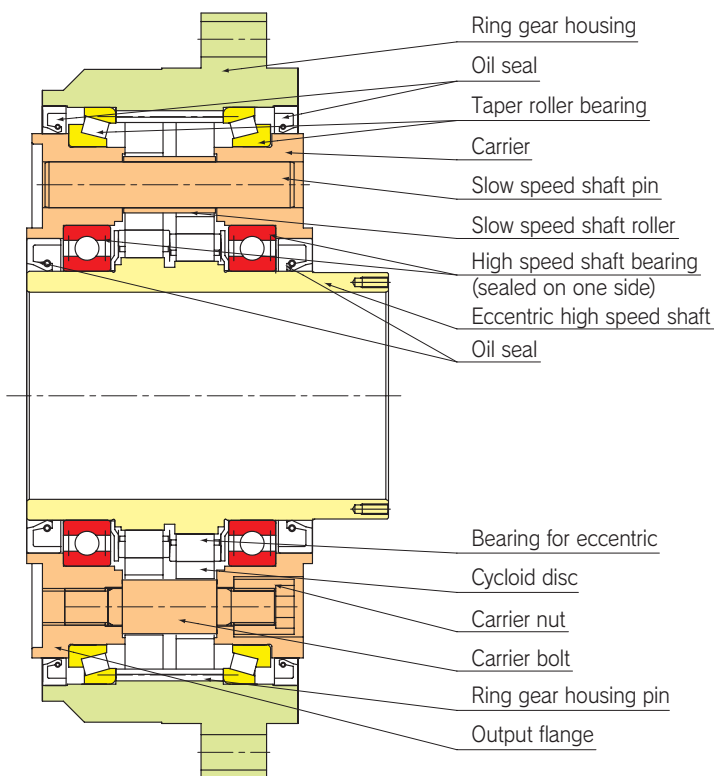

## 2. Nomenclature

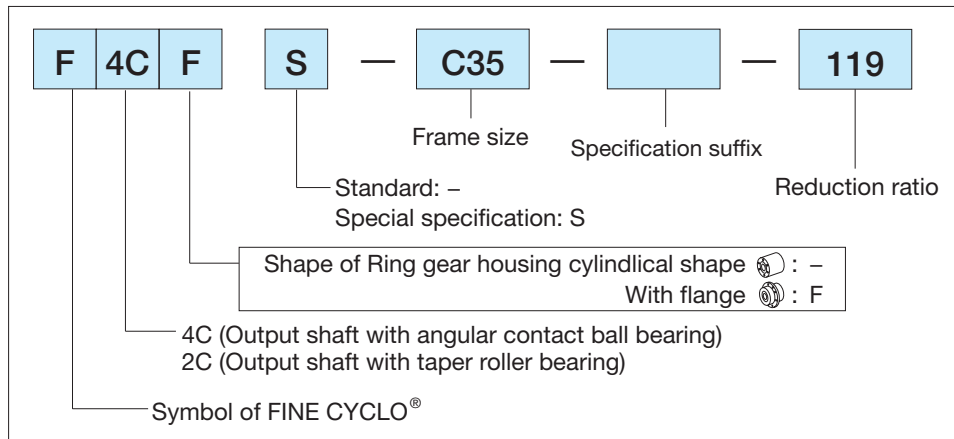

## 3. Products

Mark ● : Model Lineup

Model	Frame size	Reduction ratio		
		59	89	119
F4CF	C15	●	●	●
F4C	C25	●	●	●
F4CF	C35	●	●	●
F4CF	C45	●	●	●
F2CF	C55	●	●	●
F2CF	C65	●	●	●

## 4. Speed Ratio & Rotation Direction

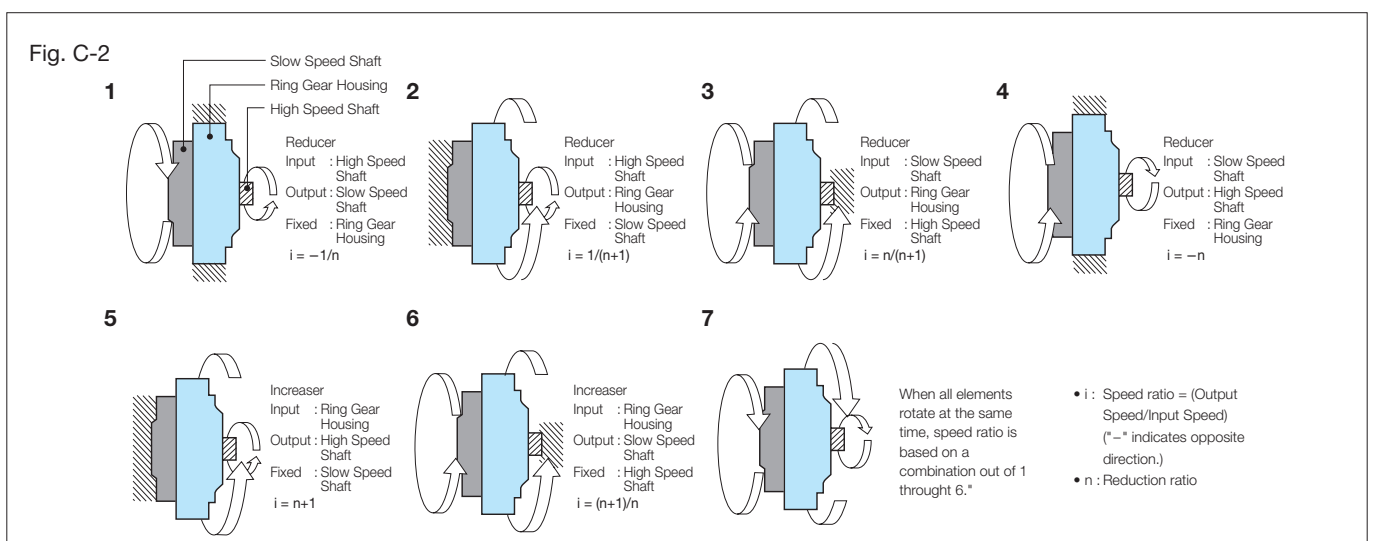

## 5. Standard Specifications

Lubrication system	Grease lubrication, the unit is filled with grease at the time of shipping. For details, refer to the chapter of "Lubrication".	
Ambient conditions	Ambient temperature	-10 to +40 °C (There is possibility of malfunctioning startup depending on rotational speed and torque of the motor at 0 °C, please consult us.)
	Ambient humidity	85% max. No condensation.
	Elevation	1000m max.
	Atmosphere	Well ventilated location, free of corrosive gases, explosive gases, vapors and dust.
	Mounting location	Indoor (free from dust, water and other liquids) Install the units where inspection, maintenance, and other operations can be carried out easily. Install the unit on a base with sufficient rigidity.
Mounting direction	No limitation.	
Painting	No painting.	

Note) For preservation, make sufficient rustproofing.

## 6. Application Examples



Industrial Robot  
Axis Driving, Robot Slider

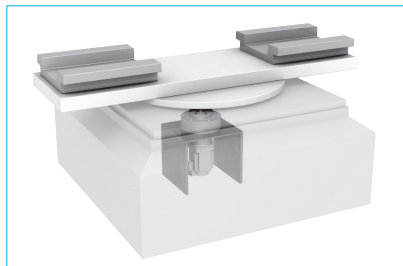

Machine Tool  
Automatic Pallet Changer Drive



Welding Positioner

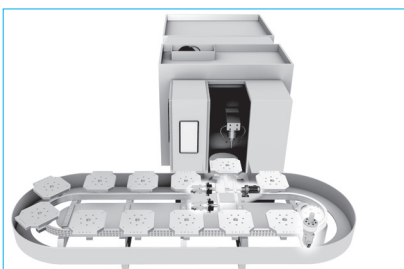

Machine Tool  
Automatic Pallet Pool Drive



Liquid Crystal Transfer Robot  
Axis Driving, Robot Slider



Liquid Crystal Transfer Robot

# 7. Rating

Table C-1 Rating Table (Input rotation base)

Input speed (r/min)			2500			2000			1750			1500		
Model	Frame size	Reduction ratio	Rated output torque (Upper/N·m) (Lower/kgf·m)	Output speed (r/min)	Allowable input power (kW)	Rated output torque (Upper/N·m) (Lower/kgf·m)	Output speed (r/min)	Allowable input power (kW)	Rated output torque (Upper/N·m) (Lower/kgf·m)	Output speed (r/min)	Allowable input power (kW)	Rated output torque (Upper/N·m) (Lower/kgf·m)	Output speed (r/min)	Allowable input power (kW)
F4CF	C15	59	193 19.7	42.4	1.14	207 21.1	33.9	0.98	215 22	29.7	0.89	225 22.9	25.4	0.80
		89	193 19.7	28.1	0.76	207 21.1	22.5	0.65	215 22	19.7	0.59	225 22.9	16.9	0.53
		119	193 19.7	21.0	0.57	207 21.1	16.8	0.48	215 22	14.7	0.44	225 22.9	12.6	0.40
F4C	C25	59	370 37.7	42.4	2.19	396 40.4	33.9	1.87	412 42	29.7	1.70	432 44.0	25.4	1.53
		89	370 37.7	28.1	1.45	396 40.4	22.5	1.24	412 42	19.7	1.13	432 44.0	16.9	1.01
		119	370 37.7	21.0	1.08	396 40.4	16.8	0.93	412 42	14.7	0.84	432 44.0	12.6	0.76
F4CF	C35	59				754 76.9	33.9	3.56	785 80	29.7	3.24	822 83.8	25.4	2.91
		89				754 76.9	22.5	2.36	785 80	19.7	2.15	822 83.8	16.9	1.93
		119				754 76.9	16.8	1.77	785 80	14.7	1.61	822 83.8	12.6	1.44
F4CF	C45	59							1275 130	29.7	5.27	1336 136	25.4	4.73
		89							1275 130	19.7	3.50	1336 136	16.9	3.14
		119							1275 130	14.7	2.61	1336 136	12.6	2.35
F2CF	C55	59										2055 209	25.4	7.28
		89										2055 209	16.9	4.83
		119										2055 209	12.6	3.61
F2CF	C65	59												
		89												
		119												

Table C-2 Momentary maximum torque

Frame size	Allowable peak torque at acceleration or deceleration		Allowable peak torque for emergency stop	
	(N·m)	(kgf·m)	(N·m)	(kgf·m)
C15	540	55.0	1080	110
C25	1030	105	2060	210
C35	1962	200	3924	400
C45	3188	325	6377	650
C55	4316	440	8633	880
C65	6278	640	12557	1280



1000			750			600			Allowable maximum input speed (r/min)	Allowable average input speed (r/min)		Equivalent On input shaft Upper/Moment of inertia (x10 <sup>-4</sup> kg·m <sup>2</sup> ) Lower/GD <sup>2</sup> (x10 <sup>-4</sup> kgf·m <sup>2</sup> )	Mass (kg)
Rated output torque (Upper/N·m) (Lower/kgf·m)	Output speed (r/min)	Allowable input power (kW)	Rated output torque (Upper/N·m) (Lower/kgf·m)	Output speed (r/min)	Allowable input power (kW)	Rated output torque (Upper/N·m) (Lower/kgf·m)	Output speed (r/min)	Allowable input power (kW)		50% ED	100% ED		
254 25.9	16.9	0.60	277 28.2	12.7	0.49	296 30.2	10.2	0.42	4000	3200	1600	3.51 14.0	6.0
254 25.9	11.2	0.40	277 28.2	8.4	0.33	296 30.2	6.7	0.28	4000	3200	1600	3.50 14.0	
254 25.9	8.4	0.30	277 28.2	6.3	0.24	296 30.2	5.0	0.21	4000	3200	1600	3.49 14.0	
487 49.7	16.9	1.15	531 54.2	12.7	0.94	568 57.9	10.2	0.81	3500	2900	1450	6.95 27.8	12.5
487 49.7	11.2	0.76	531 54.2	8.4	0.62	568 57.9	6.7	0.53	3500	2900	1450	6.90 27.6	
487 49.7	8.4	0.57	531 54.2	6.3	0.47	568 57.9	5.0	0.40	3500	2900	1450	6.90 27.6	
928 94.6	16.9	2.19	1012 103	12.7	1.79	1082 110	10.2	1.53	2500	2100	1050	28.5 114	21
928 94.6	11.2	1.45	1012 103	8.4	1.19	1082 110	6.7	1.02	2500	2100	1050	28.5 114	
928 94.6	8.4	1.09	1012 103	6.3	0.89	1082 110	5.0	0.76	2500	2100	1050	28.5 114	
1508 154	16.9	3.56	1644 168	12.7	2.91	1758 179	10.2	2.49	2100	1800	900	71.0 284	32
1508 154	11.2	2.36	1644 168	8.4	1.93	1758 179	6.7	1.65	2100	1800	900	70.9 284	
1508 154	8.4	1.77	1644 168	6.3	1.44	1758 179	5.0	1.24	2100	1800	900	70.9 283	
2321 237	16.9	5.48	2530 258	12.7	4.48	2705 276	10.2	3.83	1800	1500	750	114 456	45
2321 237	11.2	3.63	2530 258	8.4	2.97	2705 276	6.7	2.54	1800	1500	750	114 454	
2321 237	8.4	2.72	2530 258	6.3	2.22	2705 276	5.0	1.90	1800	1500	750	114 454	
3713 378	16.9	8.77	4048 413	12.7	7.17	4328 441	10.2	6.14	1700	1400	700	200 799	62
3713 378	11.2	5.82	4048 413	8.4	4.75	4328 441	6.7	4.07	1700	1400	700	199 796	
3713 378	8.4	4.35	4048 413	6.3	3.56	4328 441	5.0	3.04	1700	1400	700	199 796	

□ : 50%ED range    □ : 100%ED range

Notes:

- Rated output torque  
Rated output torque implies allowable mean load torque at each output speed. Rated output torque for below 600r/min input is the same as 600r/min.  
Allowable input power is the value converted from rated output torque, when it is 100%. This value takes efficiency of FINE CYCLO® in consideration.
- Allowable maximum input speed and allowable mean input speed  
Reducer may be used within maximum input speed indicated in the Table, however, allowable mean input speed is limited by operation (%ED).
- Allowable acceleration or deceleration peak torque  
Allowable peak torque at normal start and stop.
- Allowable momentary maximum torque  
Allowable momentary maximum torque at emergency stop or heavy shock, when loading 1000 times in overall lifetime.
- Moment of inertia, GD<sup>2</sup>  
Value at input shaft. Divide them by g (Moment of inertia: 9.8m/sec<sup>2</sup>) or 4g (GD<sup>2</sup>: 4 x 9.8m/sec<sup>2</sup>) to convert from them to inertia.
- Calculate the rated torque using the following formula when the speed is not shown in the table above.

$$T_N = T_{600} \left( \frac{600}{N} \right)^{0.3} \quad T_N : \text{Rated torque when output speed } N$$

$$T_{600} : \text{Rated torque when output speed is 600r/min}$$

# 8. Engineering Data

## 8-1. Stiffness and lost motion

- Hysteresis curve Relationship between load and displacement of output flange (rotational angle) when load is removed slowly from allowable torque to zero torque, with fixed input shaft.
- Lost Motion Torsional deflected angle at ± 3% of allowable output torque.
- Stiffness Slope of the straight line connecting two points, when allowable torque is 50% and 100% on the hysteresis curve.

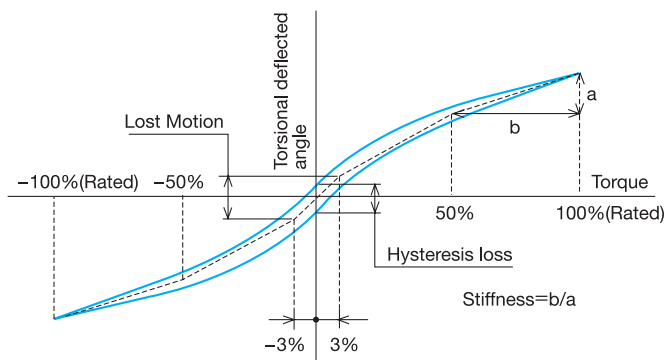

Fig. C-7 Hysteresis curve

## 8-2. No Load Running Torque

No load running torque indicates torque on input shaft for rotating reducer under no-load condition.

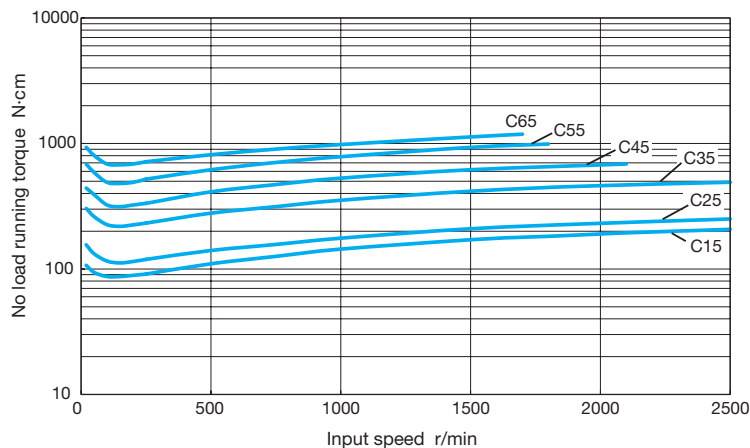

Fig. C-8

- Notes) 1. Fig. C-8 shows average data after reducers have been run.  
2. Measurement Conditions

Ring gear housing temperature	Approx. 30°C
Lubrication	Standard grease

Table C-3 Engineering data

Frame size	Rated output torque 1750r/min Up/ N·m Down/ kgf·m	Lost Motion		Stiffness Up : N·m/arc min Down : kgf·m/arc min
		Measured torque Up/ N·m Down/ kgf·m	Lost Motion arc min	
C15	215	6.5	1.0	77
	22	0.66		7.8
C25	412	12.4		128
	42	1.26		13
C35	785	23.5		294
	80	2.40		30
C45	1275	38.3		491
	130	3.90		50
C55	1962	58.9		687
	200	6.00		70
C65	3139	94.2	1030	
	320	9.60	105	

Note) Arc min means "minute" of the angle. Stiffness is the average value (typical data).

### (Example calculation of torsional deflected angle)

Calculation of torsion angle when torque is applied in one direction using C35 as example.

1) When load torque is 15N·m

(When load torque is in the range of lost motion)

$$\theta = \frac{15}{23.5} \times \frac{1}{2} = 0.32 \text{ arcmin}$$

2) When load torque is 600N·m

$$\theta = \frac{1}{2} \times \frac{600-23.5}{294} = 2.5 \text{ arcmin}$$

### 8-3. No-Load Friction Torque on Output Shaft

Indicates torque necessary to start rotation from output side of reducer from stop without load.

Table C-4 Value of no-load friction torque on output shaft

Frame size	No-load friction torque on output shaft	
	N·m	kgf·m
C15	37	3.8
C25	59	6.0
C35	118	12
C45	147	15
C55	245	25
C65	343	35

Notes: 1. Table C-4 shows average data after reducers have been run.  
2. Measurement Conditions

Accuracy in assembled dimensions	Refer Item 11-1
Lubrication	Standard grease

### 8-4. Efficiency

Fig. C-9 Efficiency Curve (Frame size C15, C25, C35 and C45)

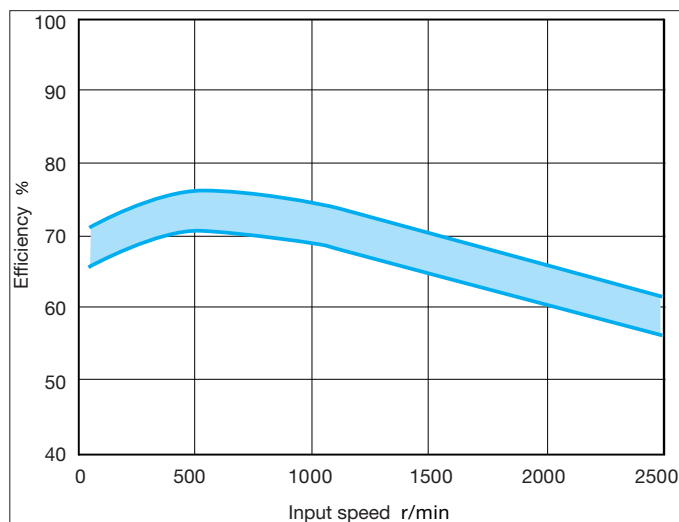

Efficiency varies by input speed, load torque, grease temperature, reduction ratio, etc.

Fig. C-9 and C-10 indicates efficiency vs. input speed at allowable output torque with stable grease temperature.

Efficiency curve is indicated with flexible coverage for variations in models and reduction ratio.

Fig. C-10 (Frame size C55-C65)

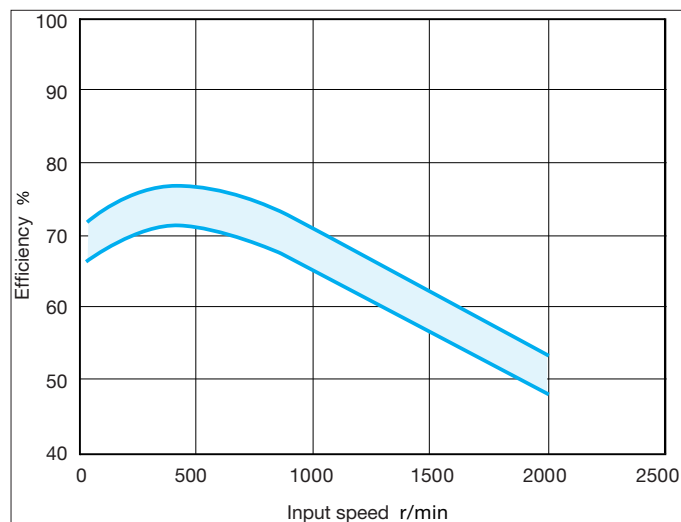
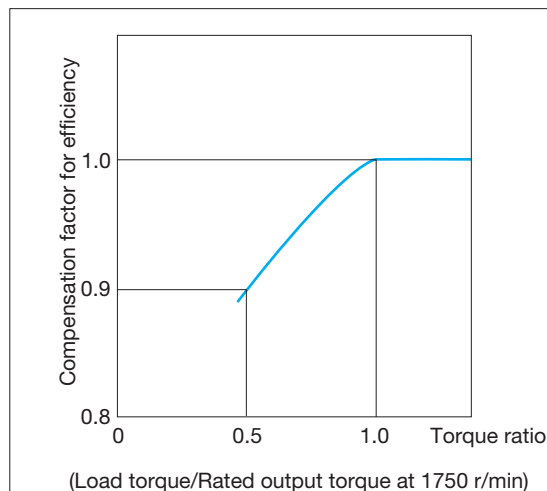

Fig. C-11 Compensation Curve of Efficiency



Compensation efficiency=Efficiency(Fig.C-9, Fig. C-10) x Compensation factor for efficiency(Fig.C-11)

- Note) 1. Efficiency varies when load torque differs with allowable torque. Check the compensation factor in the left diagram.  
2. When torque ratio is over 1.0, compensation factor for efficiency is 1.0.

### 8-5. ALLOWABLE RADIAL LOAD & AXIAL LOAD OF HIGH SPEED SHAFT

When a gear or sheave is mounted on the high speed shaft, radial load and axial load should be equal to or less than allowable value. Check radial & axial load by following the next formula (1)-(3).

(1) Radial load  $P_r$

$$P_r = \frac{T \ell}{R} \leq \frac{P_{ro}}{L_f \cdot C_f \cdot F_{S1}} \quad [\text{N, kgf}] \quad (\text{Formula C-1})$$

(2) Axial load  $P_a$

$$P_a \leq \frac{P_{ao}}{C_f \cdot F_{S1}} \quad [\text{N, kgf}] \quad (\text{Formula C-2})$$

(3) When radial and axial load co-exist

$$\left( \frac{P_r \cdot L_f}{P_{ro}} + \frac{P_a}{P_{ao}} \right) \cdot C_f \cdot F_{S1} \leq 1 \quad (\text{Formula C-3})$$

$P_r$  : Actual radial load [N, kgf]

$T \ell$  : Equivalent torque on input shaft [N·m, kgf·m]

$R$  : Pitch circle radius of sprocket, gear, or sheave [m]

$P_{ro}$  : Allowable radial load [N, kgf] (Table C-5)

$P_a$  : Actual axial load [N, kgf]

$P_{ao}$  : Allowable axial load [N, kgf] (Table C-6)

$L_f$  : Load location factor (Table C-7)

$C_f$  : Coupling factor (Table C-8)

$F_{S1}$  : Shock factor (Table C-9)

Table C-5 Allowable radial load  $P_{ro}$ (Up: N/Down: kgf)

Frame size	Input speed r/min						
	2500	2000	1750	1500	1000	750	600
C15	384	453	491	534	655	748	825
	39	46	50	54	67	76	84
C25	523	563	589	620	709	781	841
	53	57	60	63	72	80	86
C35		657	687	723	828	911	981
		67	70	74	84	93	100
C45			785	826	946	1041	1121
			80	84	96	106	114
C55				981	1123	1236	1332
				100	114	126	136
C65					1419	1561	1682
					145	159	171

Table C-6 Allowable axial load  $P_{ao}$ (Up: N/Down: kgf)

Frame size	Input speed r/min						
	2500	2000	1750	1500	1000	750	600
C15	432	479	509	546	658	751	832
	44	49	52	56	67	77	85
C25	540	589	628	677	824	942	1040
	55	60	64	69	84	96	106
C35		746	795	863	1040	1197	1334
		76	81	88	106	122	136
C45			912	981	1197	1373	1530
			93	100	122	140	156
C55				1481	1785	2050	2276
				151	182	209	232
C65					2570	2953	3286
					262	301	335

Table C-7 Load Location Factor  $L_f$

L (mm)	Frame size					
	C15	C25	C35	C45	C55	C65
5	0.79	0.80	0.76	0.75	0.73	0.73
10	0.86	0.86	0.81	0.79	0.77	0.77
15	0.93	0.92	0.86	0.83	0.80	0.80
20	1.00	0.98	0.90	0.87	0.84	0.84
25	1.25	1.14	0.95	0.91	0.88	0.87
30	1.50	1.36	1.00	0.95	0.91	0.90
35	1.75	1.59	1.17	0.99	0.95	0.94
40	2.00	1.82	1.33	1.11	0.99	0.97
45	2.25	2.05	1.50	1.25	1.07	1.02
50	2.50	2.27	1.67	1.39	1.19	1.14
60	3.00	2.73	2.00	1.67	1.43	1.36
70				1.94	1.67	1.59
80					1.90	1.82
$L_f = \text{When } 1 \text{ of } L(\text{mm})$	20	22	30	36	42	44

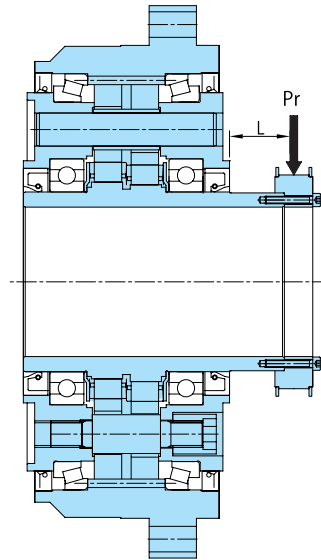

Fig. C-12 Load location on input shaft

Table C-8 Coupling Factor  $C_f$

Coupling method	$C_f$
Chain	1
Machine gear or pinion	1.25
Timing belt	1.25
V-Belt	1.5

Table C-9 Shock Factor  $F_{S1}$

Degree of shock	$F_{S1}$
Practically no shock	1
Light shock	1-1.2
Severe shock	1.4-1.6

# 9. Main Bearings

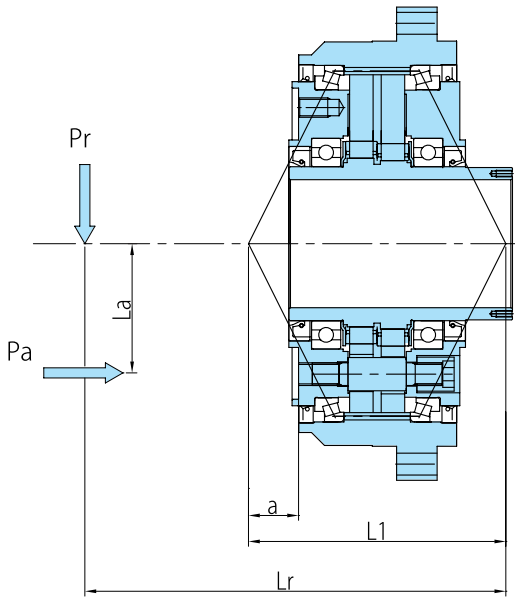

Fig. C-13 Span between each loading point  
Note) Consult us if:  $L_r > 4 \times L_1$

### 1. Moment Stiffness

Indicates stiffness on inclination of output shaft with external moment.

External moment (M)

$$M = Pr \cdot L_r + Pa \cdot L_a \dots \dots \dots \text{(Formula C-4)}$$

### 2. Allowable Moment & Allowable Axial Load

Check external moment and external axial load with Formula C-5, Formula C-6, and Fig.C-13.

Equivalent moment (Me)

$$M_e = C_f \cdot F_{S1} \cdot Pr \cdot L_r + C_f \cdot F_{S1} \cdot Pa \cdot L_a \dots \dots \dots \text{(Formula C-5)}$$

Equivalent axial load (Pae)

$$P_{ae} = C_f \cdot F_{S1} \cdot Pa \dots \dots \dots \text{(Formula C-6)}$$

$C_f$  : Coupling factor [Table C-13]

$F_{S1}$  : Shock factor [Table C-14]

Pr: Actual radial load(N, kgf)  
Pa: Actual axial load(N, kgf)

Table C-10 Span of Loading Points(mm)

Frame size	Span of Loading Points	
	L1(mm)	a(mm)
C15	130.6	33.2
C25	162.0	43.3
C35	196.2	54.9
C45	226.3	63.9
C55	191.8	41.9
C65	211.8	46.4

Table C-11 Moment Stiffness

Frame size	Moment Stiffness	
	(N·m/arcmin)	(kgf·m/arcmin)
C15	584	59.5
C25	956	97.5
C35	1668	170
C45	2649	270
C55	3924	400
C65	5690	580

Table C-12 Allowable Moment & Allowable Axial Load

Frame size	Allowable Moment		Allowable Axial Load	
	(N·m)	(kgf·m)	(N)	(kgf)
C15	1069	109	3924	400
C25	1850	188	7848	800
C35	2850	290	10791	1100
C45	4316	440	10791	1100
C55	6082	620	10791	1100
C65	8829	900	13734	1400

Table C-13 Coupling Factor Cf

Load connection factor	Cf
General purpose chain	1
Machine gear or pinion	1.25
Timing belt	1.25
V-Belt	1.5

Table C-14 Shock factor FS1

Load Classification	FS1
Uniform load (no shock)	1
Moderate shocks	1-1.2
Heavy shocks	1.4-1.6

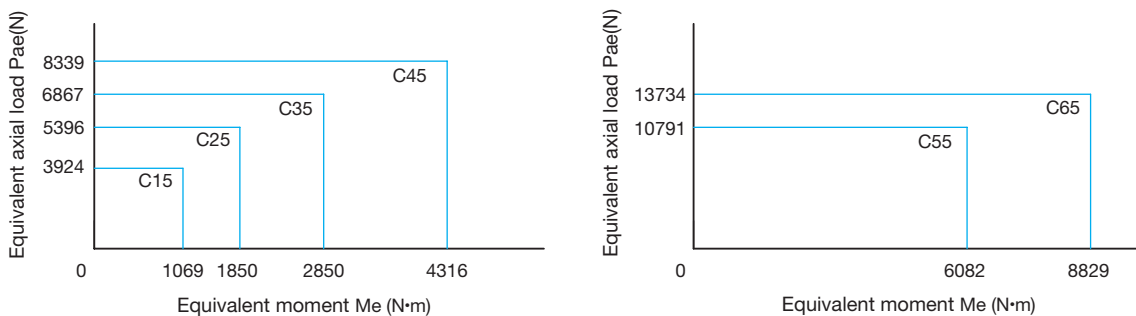
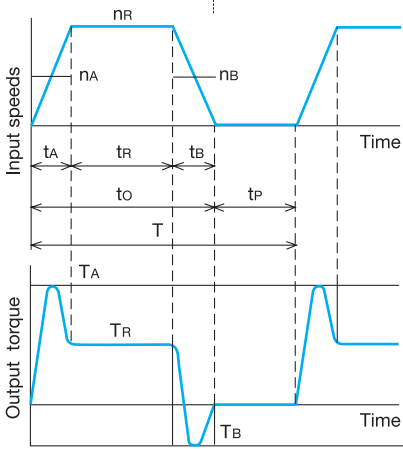

Fig. C-14 Diagram of Allowable Moment & Axial Load

# 10. Selection

## 10-1. Flow Cart and Formula of Selection

Fig. C-15 Load cycle



$n_A$  : Average input speed during acceleration under condition defined in Fig. C-15

$$n_A = \frac{n_R}{2}$$

$n_R$  : Input speed with normal running

$n_B$  : Average input speed during deceleration in Fig. C-15

$$n_B = \frac{n_R}{2}$$

$t_A$  : Acceleration time  
 $t_R$  : Normal running time  
 $t_B$  : Deceleration time  
 $t_o$  : Total running time  
 $t_P$  : Standstill time

$T$  : Time/Cycle  
 $T_A$  : Acceleration peak torque  
 $T_R$  : Torque during normal running  
 $T_B$  : Peak torque at braking

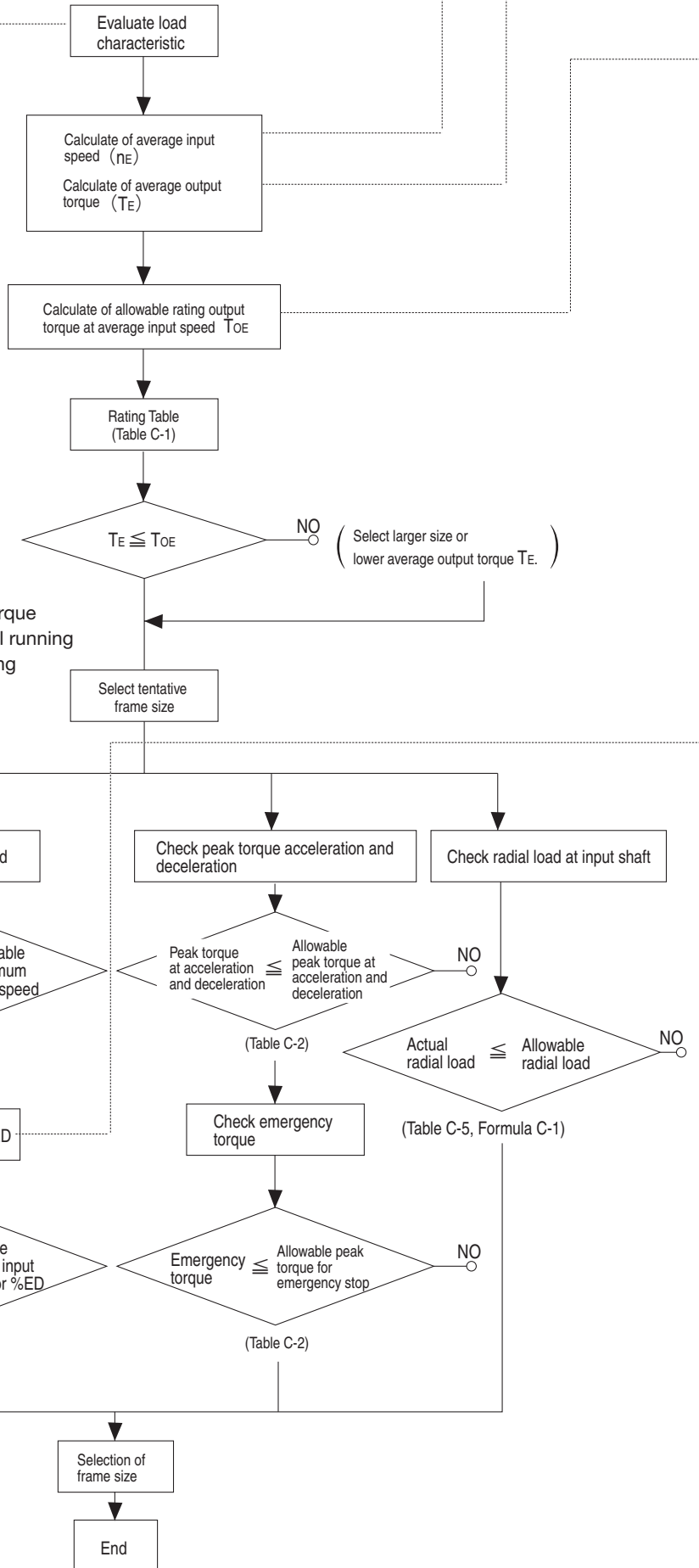

Calculation in Load Condition of Fig. C-15

○ Average input speed  $n_E = \left( \frac{t_A \cdot n_A + t_R \cdot n_R + t_B \cdot n_B}{t_o} \right)$  .....(Formula C-8)

○ Average output torque  $T_E = \left( \frac{t_A \cdot n_A \cdot T_A^{10/3} + t_R \cdot n_R \cdot T_R^{10/3} + t_B \cdot n_B \cdot T_B}{t_o} \right)^{0.3} \times F_{S2}$  .....(Formula C-9)

○ Allowable rating output torque at average input speed  $T_{OE} = \left( \frac{600}{n_E} \right)^{0.3} \times T_o$  .....(Formula C-10)

To: Rated output torque at input speed 600r/min (Table C-2)  
When  $n_E < 600$ ,  $T_{OE}$  equals to  $T_o$  at input speed 600r/min.

○ %ED  $\%ED = \frac{t_o}{T} \times 100$  .....(Formula C-11)

Maximum of single cycle time is 10 minutes when calculating %ED. When single cycle time is over 10 minutes, calculate %ED as T =10 (minutes).

Table C-15  $F_{S2}$  Load factor

Loading condition	$F_{S2}$
Uniform load	1
Moderate shock	1~1.2
Heavy shock	1.4~1.6

10-2. Example of Selection

Evaluate F4C-C25-119 for following specification.

- |  |           |   |        |
|--|-----------|---|--------|
| (Specification) $T_A$ : Acceleration peak torque | 600N·m    | $t_A$ : Acceleration time   | 0.3sec |
| $T_R$ : Normal running torque                    | 250N·m    | $t_R$ : Normal running time   | 3.0sec |
| $T_B$ : Peak torque at breaking                  | 400N·m    | $t_B$ : Deceleration time   | 0.3sec |
| Emergency torque : 1700N·m                       |           | $t_P$ : Standstill time   | 3.6sec |
| (1000 times during overall life time)            |           | $t_o$ : Total running time  | 3.6sec |
| $n_A$ : Average input speed during acceleration  | 1250r/min | T : Single cycle time   | 7.2sec |
| $n_R$ : Input speed with normal running          | 2500r/min | Radial load at input shaft : Operated by timing belt with moderate shock 196N at point 25mm from end of shaft |        |
| $n_B$ : Average input speed during deceleration  | 1250r/min | Radial load at output shaft : Connection with gear, moderate shock 4116N at 60mm point from side of flange    |        |

It considered that reducer is used to operate wrist of robot with moderate shock.

(Calculate) Average input speed  $n_E = \frac{0.3 \times 1250 + 3.0 \times 2500 + 0.3 \times 1250}{3.6} = 2292(r/min)$

Average output torque  $T_E = \left( \frac{0.3 \times 250 \times 600^{10/3} + 3.0 \times 2500 \times 250^{10/3} + 0.3 \times 1250 \times 400^{10/3}}{3.6 \times 2292} \right) \times 1 = 306(N \cdot m)$

○ Allowable output torque at average input speed  $T_{OE} = \left( \frac{600}{2292} \right)^{0.3} \times 568 = 380(N \cdot m) \geq 306(N \cdot m) \rightarrow F4C-C25-119$

○ Calculate of %ED  $\%ED = \frac{3.6}{7.2} \times 100 = 50\%$

○ Evaluate of maximum input speed 2500(r/min) < 3500(r/min) (Table C-1)

○ Evaluate of average input speed 2292(r/min) at 50%ED < 2900(r/min) at 50%ED (Table C-1)

○ Evaluate of peak torque at acceleration and deceleration 600(N·m) < 1030(N·m) (Table C-2)

○ Evaluate of emergency torque 1700(N·m) < 2060(N·m) (Table C-2)

○ Allowable radial load at input shaft with coefficient in consideration

$Pro = 538N = 841 \times (600/2292)^{1/3}$ ,  $Lf = 1.08$ ,  $Cf = 1.25$ ,  $F_{S1} = 1.2$

$\frac{Pro}{Lf \times Cf \times F_{S1}} = \frac{538}{1.08 \times 1.25 \times 1.2} = 332(N) > 196(N)$  (Table C-5, Formula C-1)

○ Evaluate of allowable moment

$Lr = 55 + L1 - a = 55 + 102 - 13.5 = 143.5$

External Moment Calculated with the Coefficient

$Cf = 1.25$ ,  $F_{S1} = 1.2$ ,  $M = Cf \times F_{S1} \times Pr \times Lr = 1.25 \times 1.2 \times 4116 \times 143.5 = 886(N \cdot m) < 1850(N \cdot m)$

F4C-C25-119 is selected by evaluation above.

# 11. Notice for Designing

## 11-1 Assembly method and tolerances

Fig. C-16 Assembly Method

- Pilot for mounting input parts(Pully, Gear etc.) are as (C) in following figure.
- Use (B) for output shaft assembly and (A) for casing assembly as pilot for mounting.

Example for Assembly 1

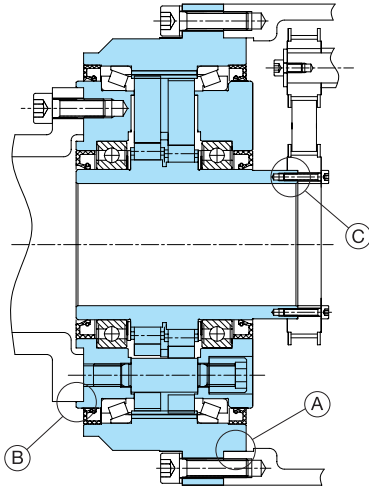

## 11-2. Tightening Torque and Allowable Transmitted Torque for Bolts

### 1 Allowable transmitted torque for bolts

Quantity, size, and tightening torque of bolt for the output flange and ring gear housing are shown in Table C-16. Allowable peak torque for emergency stop that can be transmitted is shown in Table C-16.

Table C-16

Frame size	Output Flange Bolts					Ring gear housing bolts				
	Number of bolts-size	Tightening torque		Allowable transmitted torque by bolts		Number of bolts-size	Tightening torque		Allowable transmitted torque by bolts	
		N·m	kgf·cm	N·m	kgf·cm		N·m	kgf·cm	N·m	kgf·cm
C15	16-M6	13.6	139	1252	128	12-M6	13.6	139	1520	155
C25	12-M8	33.4	340	2080	212	12-M8	33.4	340	3178	324
C35	12-M10	65.7	670	4267	435	8-M10	65.7	670	4670	476
C45	12-M12	114	1160	7191	733	8-M12	114	1160	7760	791
C55	12-M14	181	1850	10919	1113	12-M12	114	1160	13008	1326
C65	12-M16	284	2890	16893	1722	16-M12	114	1160	19404	1978

Frame size	Eccentric High Speed Shaft				
	Number of bolts-size	Tightening torque		Allowable transmitted torque by bolts	
		N·m	kgf·cm	N·m	kgf·cm
C15	6-M3	1.67	17	57	5.8
C25	6-M3	1.67	17	69	7.0
C35	6-M4	3.92	40	157	16
C45	6-M4	3.92	40	196	20
C55	8-M5	8.04	82	481	49
C65	12-M5	8.04	82	785	80

- Bolt: Use metric hexagon socket head cap screw based on JIS B1176, strength grade 10.9"
- Countermeasure for bolts loosening: Use adhesives (Loctite262, etc.) or spring washer (based on JIS B1251, class 2).
- Use conical spring washer (Based on JIS B1251, class 2) on flange side when coupling the reducer to prevent damaging the bolt bearing surface.
- Friction Coefficient: 0.15



### 11-3. Assembly Procedure

Example for Assembly 1

(1)

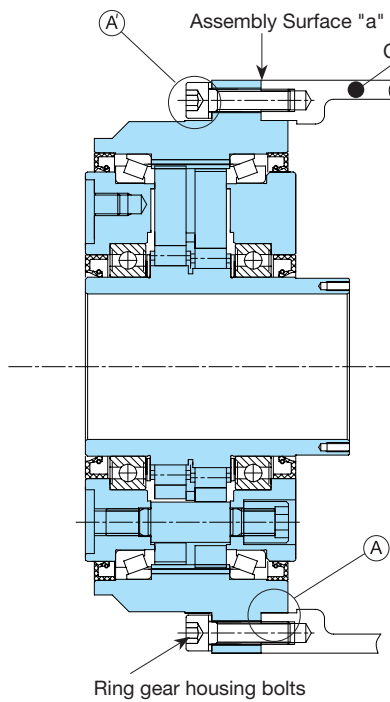

FINE CYCLO® is attached to the casing of machine with bolts. (Pilot (A))  
 Oposit side (Pilot (A)) can be used for attaching to the casing of machine.  
 Apply liquid gasket to the assembly side "a" at this point.

(2)

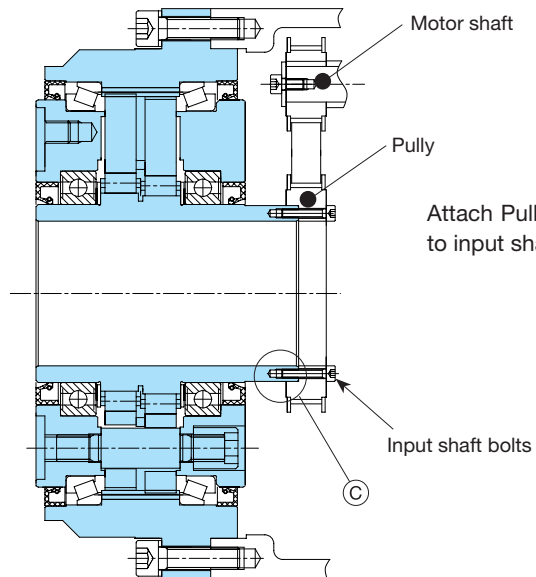

Attach Pulley or equivalent parts to input shaft with bolts.

(3)

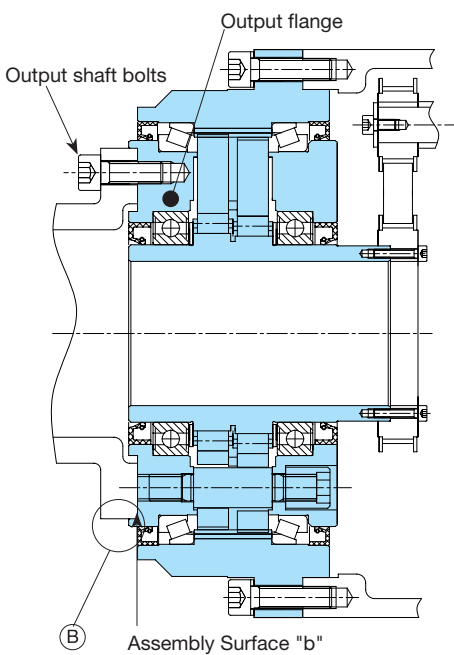

Attach Output flange of FINE CYCLO® to output shaft of machine by bolts. (Pilot (B))

Notes1) Make sure to apply specified tightening torque (refer to Table C-16) to bolts when attaching reducer.

Notes2) Choose bolts shorter then the depth of tap indicated in output side flange and input shaft in Outline Drawing.

Recommended liquid gasket: Liquid gasket Three Bond 1215 of Three Bond Co., Ltd.

### 11-4. Lubrication

- Grease supply at the time of assembly is not necessary. FINE CYCLO® is filled with grease (Multemp FZ No. 00) before shipment to customer.
- Overhaul recommended when reducer runs for total 20000 hours or 3-5 years after purchase.

Table C-18

Unit: g

Frame size	C15	C25	C35	C45	C55	C65
Grease(g)	45	75	110	170	200	300

# 12. Outline Drawing

## F4CF-C15

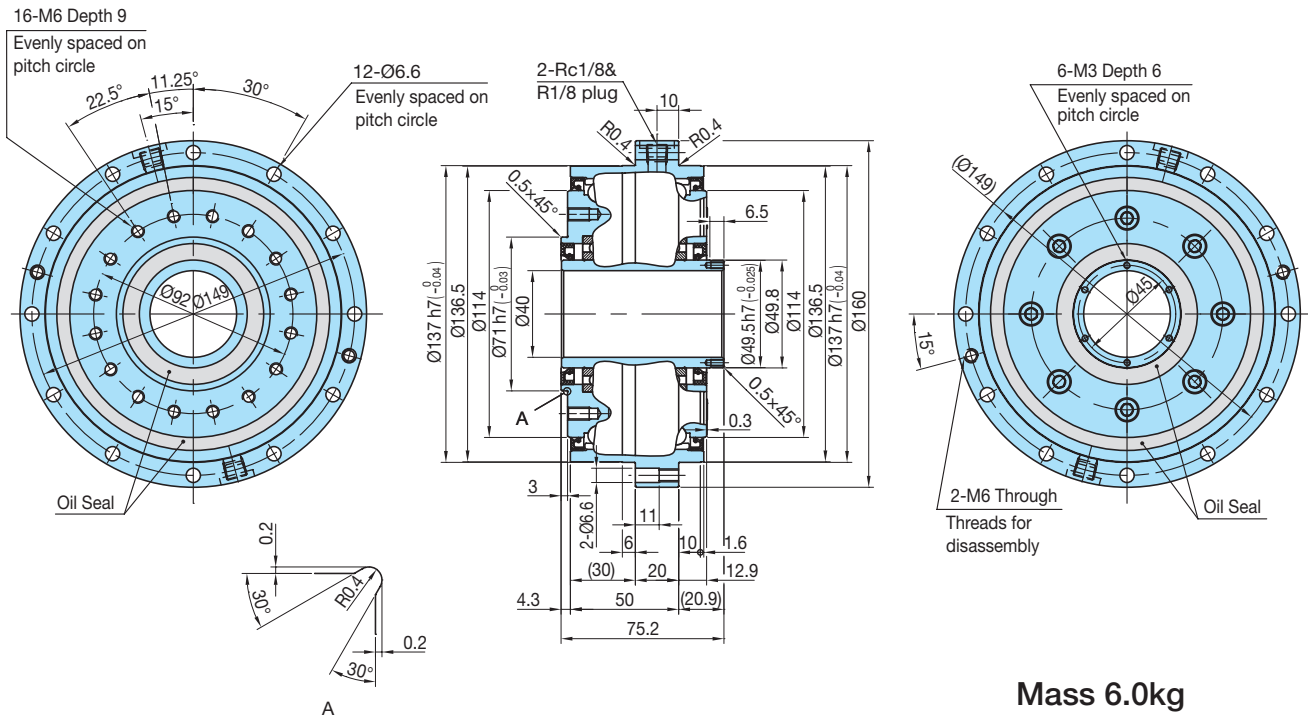

Mass 6.0kg

## F4C-C25

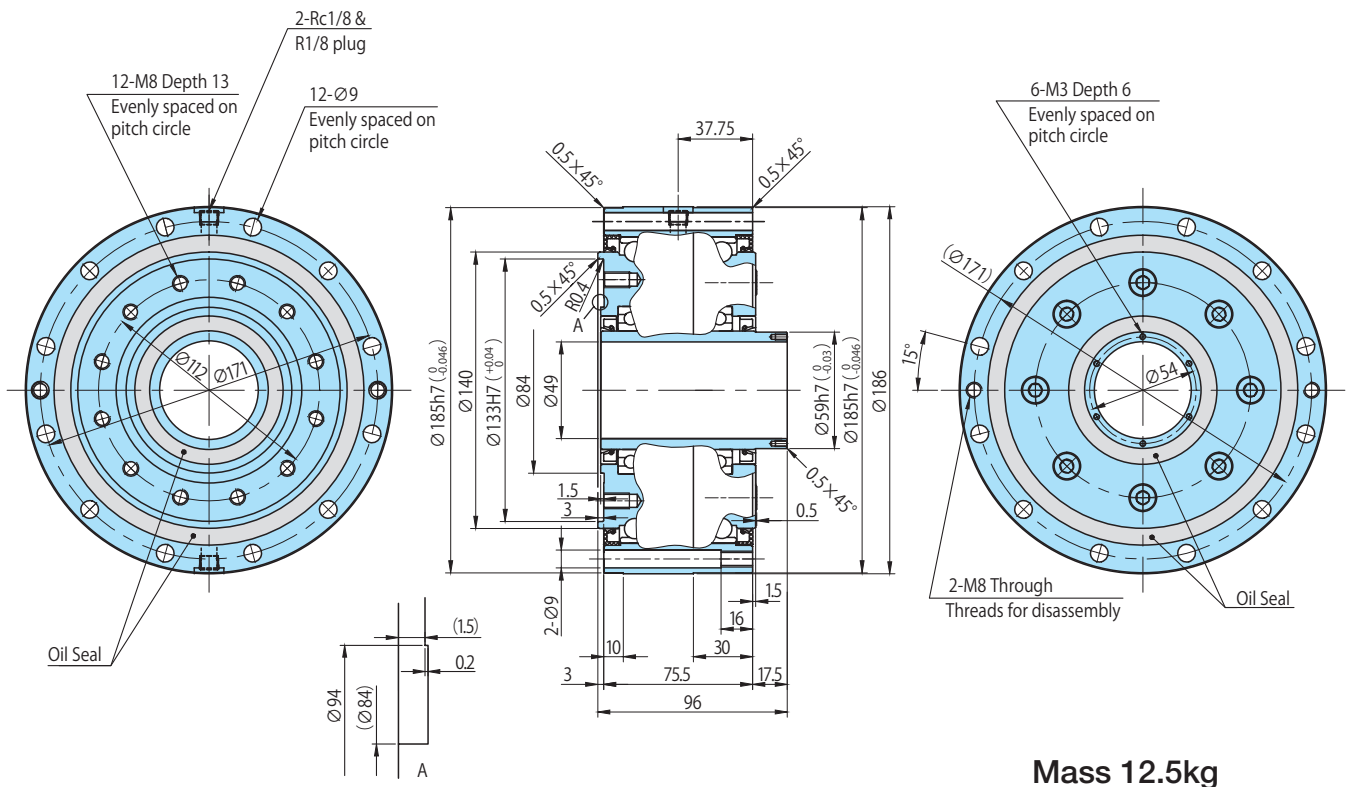

Mass 12.5kg

# Outline Drawing

## F4CF-C35

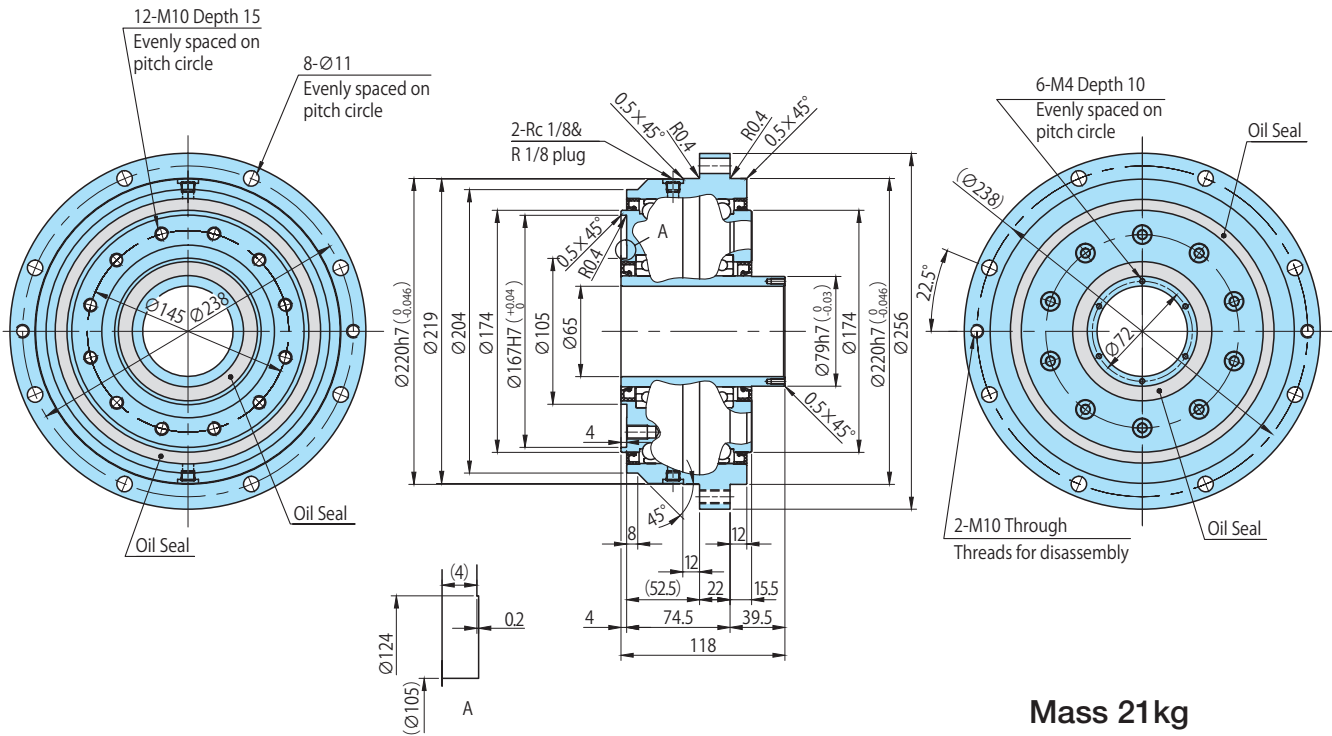

## F4CF-C45

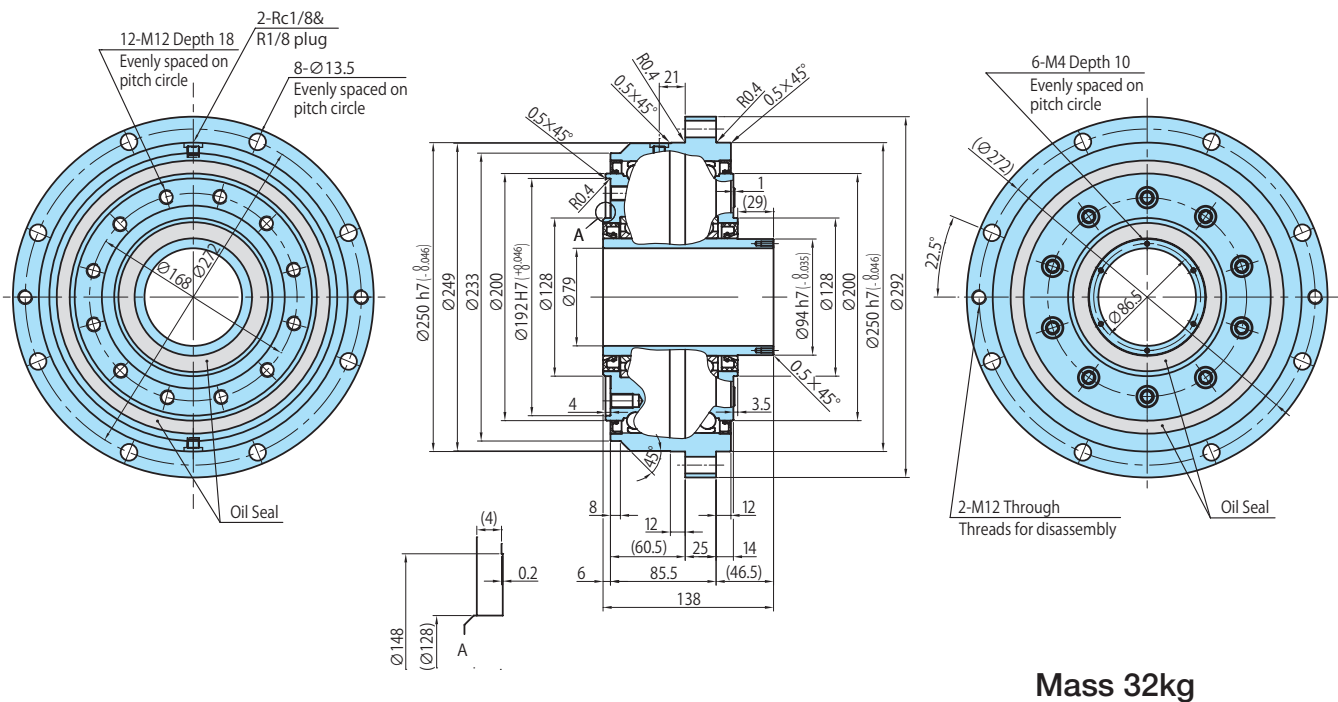

# Outline Drawing

## F2CF-C55

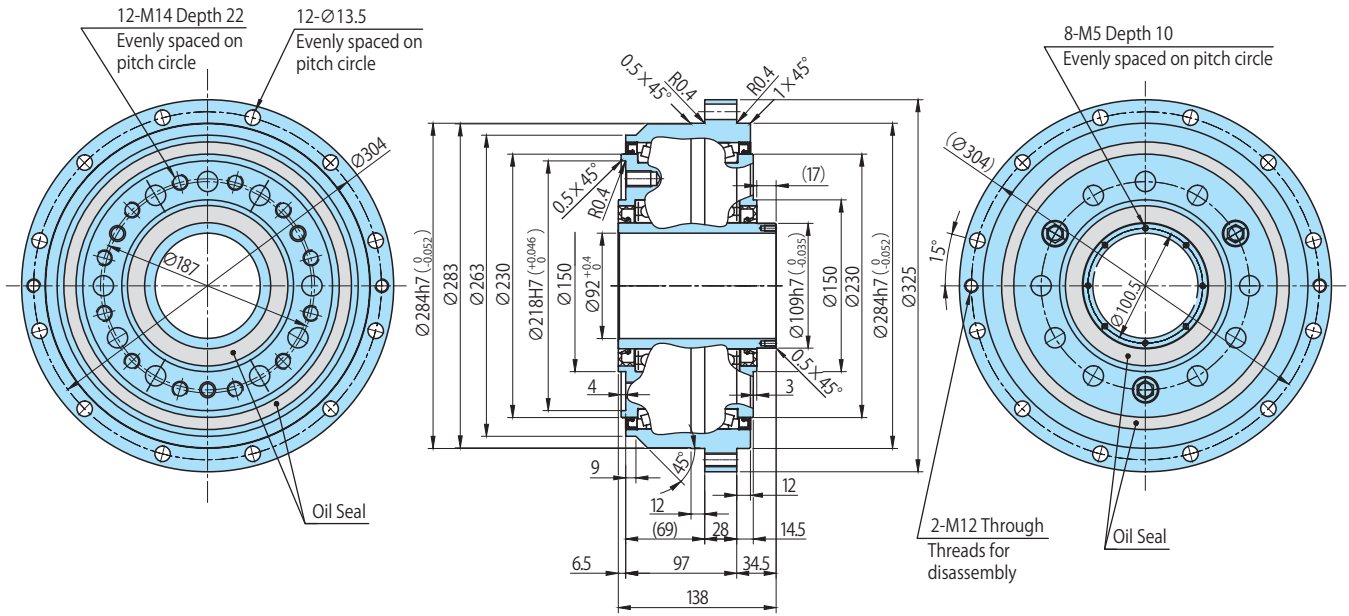

Mass 45kg

## F2CF-C65

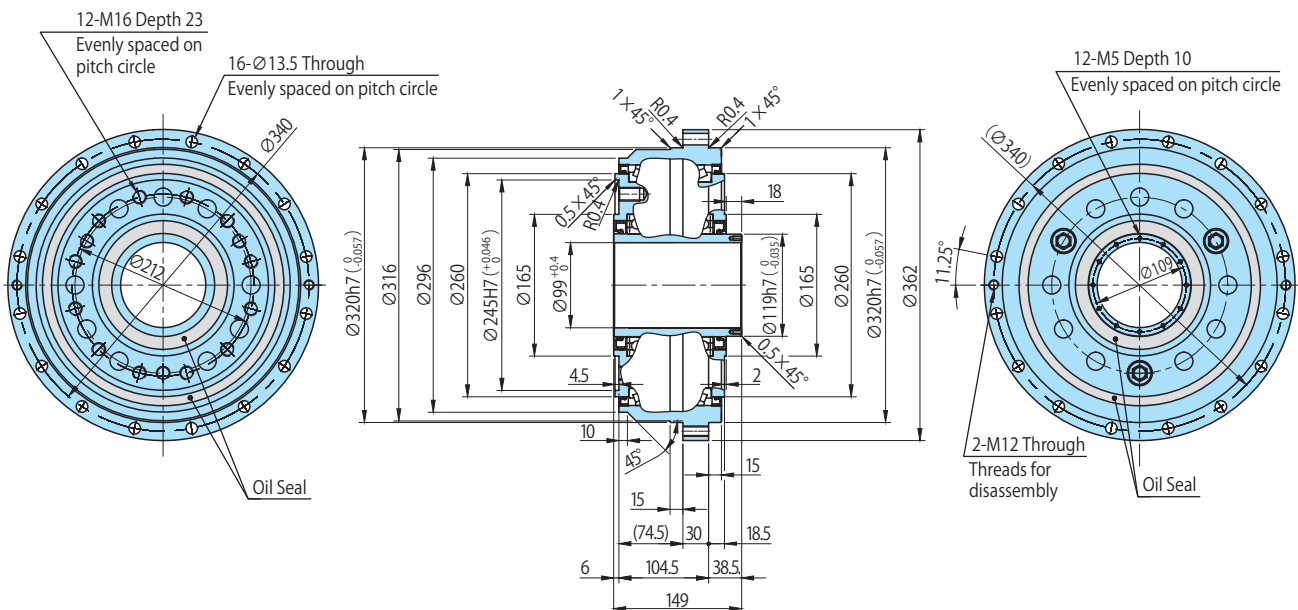

Mass 62kg

# 13. Operating Principles

The reducer portion of the FINE CYCLO® is fundamentally different in principle and mechanism from the involute gearing mechanism of competitive gearmotors. The unique speed reducer portion is an ingenious combination of the following two mechanisms:

- ☆ A combination of a planet gear and a fixed internal sun gear. In the FINE CYCLO®, the planet gear has cycloidal-shaped teeth and the sun gear has circular pin teeth. The number of teeth in the planet gear is one or two less than the sun gear.
- ☆ A constant speed internal gearing mechanism.

Fig. C-3 Principle of internal Planetary Gearing

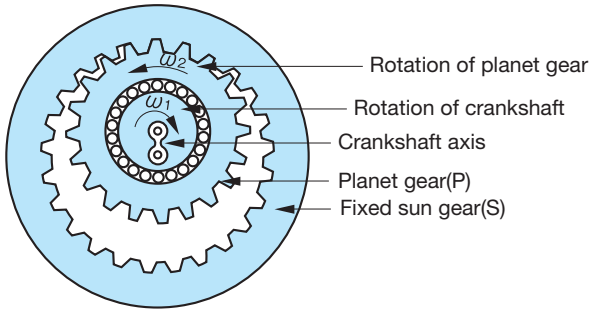

See Fig. C-3

In equation 1, below, P identifies the number of the planet gear teeth, S that of the sun gear,  $\omega_2$  the angular velocity of the planet gear around its own axis. The velocity ratio of  $\omega_2$  to  $\omega_1$  is shown as follows:

$$\frac{\omega_2}{\omega_1} = 1 - \frac{S}{P} = -\frac{S-P}{P} \quad \dots \text{Equation 1}$$

With S greater by one or two than P in this equation, the highest velocity ratio is obtainable.

That is, if  $S-P=1$  is applied to Equation 1, the velocity ratio may be calculated from the following equation:

$$\frac{\omega_2}{\omega_1} = \frac{1}{P} \quad \dots \text{Equation 2}$$

Or if  $S-P=2$  is applied to Equation 1, the velocity ratio may be calculated from the following equation:

$$\frac{\omega_2}{\omega_1} = \frac{2}{P} \quad \dots \text{Equation 3}$$

As the crankshaft rotates at the angular velocity  $\omega_1$  around the axis of the sun gear, the planet gear rotates at the angular velocity:

$$-\frac{1\omega_1}{P} \text{ or } -\frac{2\omega_1}{P}$$

when P indicates the number of the teeth of the planet gear and the symbol indicates that the rotation of the planet gear is in a reverse direction to that of the crankshaft.

In the FINE CYCLO®, illustrated in Fig. C-4, circular teeth(pins) are adapted for the sun gear and epitrochoid curved teeth for the planet gear, thereby avoiding tooth top interference. The rotation of the planet gear around its own axis is taken out through a constant speed internal gearing mechanism as shown in Fig. C-5.

In this mechanism shown in Fig. C-6, the pins of the slow speed shaft are evenly spaced on a circle that is concentric to the axis of the sun gear. The pins transmit the rotation of the planet gear by rolling internally on the circumference of the bores of each planet gear or cycloid disc. The diameter of the bores minus the diameter of the slow speed shaft pins is equal to twice the eccentricity value of the crank shaft (eccentric). This mechanism smoothly transmits only the rotation of the planet gear around its own axis to the slow speed shaft.

Fig. C-4 Epitrochoid Planet Gear-Circular(PIN) Tooth Sun Gear Combination

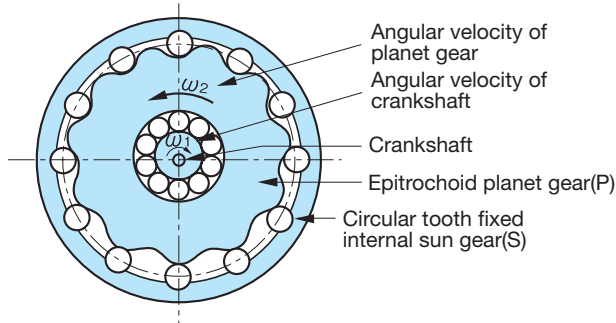

Fig. C-5 Constant Speed Internal Gearing

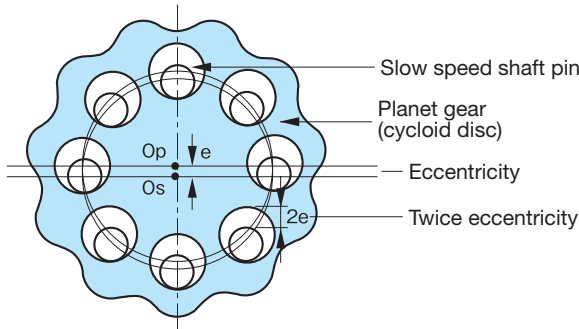
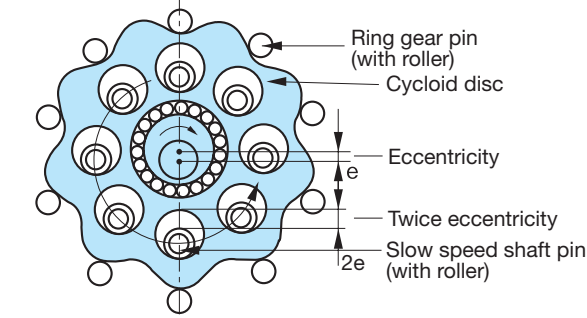

Fig. C-6 Combination of Planet-Sun Gears and Constant Speed Internal Gear



# Warranty

The scope of our warranty for our products is limited to the range of our manufacture.

Warranty (period and contents)

Warranty Period	The warranty period for the Products shall be 18 months after the commencement of delivery or 18 months after the shipment of the Products from the seller's works or 12 months from the Products coming into operation, whichever comes first.
Warranty Condition	<p>In the event that any problem or damage to the Product arises during the "Warranty Period" from defects in the Product whenever the Product is properly installed and combined with the Buyer,s equipment or machines, maintained as specified in the maintenance manual, and properly operated under the conditions described in the catalog or as otherwise agree upon in writing between the Seller and the Buyer or its customers ; the Seller will provide, at its sole discretion, appropriate repair or replacement of the Product without charge at a designated facility, except as stipulated in the "Warranty Exclusions" as described below.</p> <p>However, if the Product is installed or integrated into the Buyer,s equipment or machines, the Seller shall not reimburse the cost of : removal or re-installation of the Product or other incidental costs related thereto, any lost opportunity, any profit loss or other incidental or consequential losses or damages incurred by the Buyer or its customers.</p>
Warranty Exclusions	<p>Notwithstanding the above warranty, the warranty as set forth herein shall not apply to any problem or damage to the Product that is caused by :</p> <ol style="list-style-type: none"> <li>1. installation, connection, combination or integration of the Product in or to the other equipment or machine that is rendered by any person or entity other than the Seller ;</li> <li>2. insufficient maintenance or improper operation by the Buyer or its customers, such that the Product is not maintained in accordance with the maintenance manual provided or designated by the Seller ;</li> <li>3. improper use or operation of the Product by the Buyer or its customers that is not informed to the Seller, including, without limitation, the Buyer,s or its customers, operation of the Product not in conformity with the specifications, or use of lubricating oil in the Product that is not recommended by the Seller ;</li> <li>4. any problem or damage on any equipment or machine to which the Product is installed, connected or combined or on any specifications particular to the Buyer or its customers ;</li> <li>5. any changes, modifications, improvements or alterations to the Product or those functions that are rendered on the Product by any person or entity other than the Seller ;</li> <li>6. any parts in the Product that are supplied or designated by the Buyer or its customers ;</li> <li>7. earthquake, fire, flood, sea-breeze, gas, thunder, acts of God or any other reasons beyond the control of the Seller ;</li> <li>8. normal wear and tear, or deterioration of the Product,s parts, such as bearings, oil-seals ;</li> <li>9. any other troubles, problems or damage to the Product that are not attributable to the Seller.</li> </ol>

